

MILL DRILL MACHINE HM-46B

Order Code: (M139D)

Edition : 1.0
Date: (05/24)

The following section covers the spare parts diagrams and lists that were current at the time this manual was originally printed. Due to continuous improvements of the machine, changes may be made at anytime without notification.

HOW TO ORDER SPARE PARTS

1. Have your machines model number, serial number & date of manufacture on hand, these can be found on the specification plate mounted on the machine
2. A scanned copy of your parts list/diagram with required spare part/s identified.

NOTE: SOME PARTS MAY ONLY BE AVAILABLE AS AN ASSEMBLY

3. Go to www.machineryhouse.com.au/contactus and fill out the inquiry form attaching a copy of scanned parts list.



WARNING!

*Electricity is dangerous and could cause death
All electrical work must be carried out by a qualified electrician.*



CAUTION

It is impossible to cover all possible hazards Every workshop enviroment is different. These are designed as a guide to be used to compliment training and as a reminder to users prior to equipment use. Always consider safety first, as it applies to the individual working conditions.

HEAD PARTS DIAGRAM

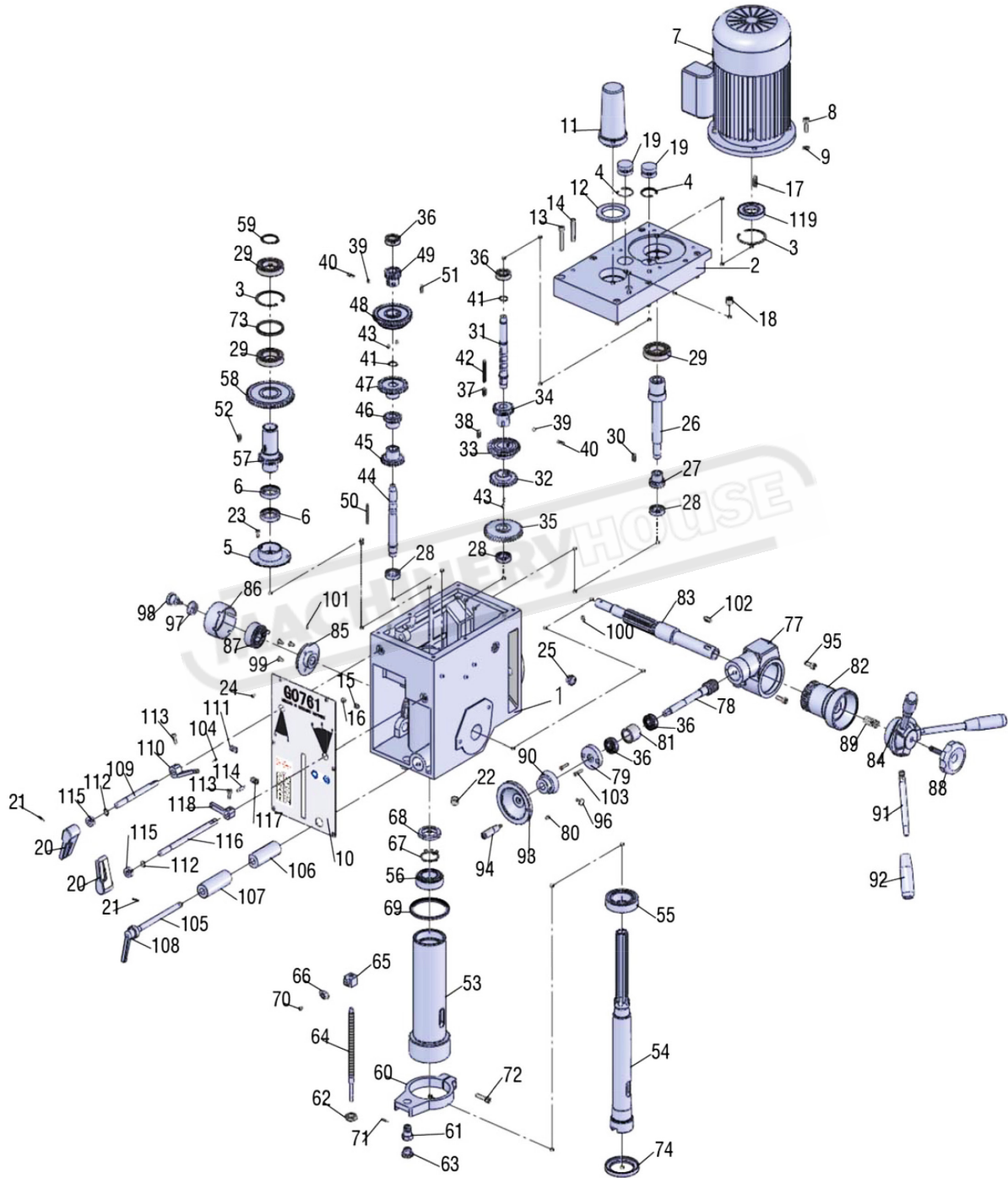

HEAD PARTS LIST

No.	Qty.	Code.	Name	No.	Qty.	Code.	Name
1	1	20010B	Head Body	37	1	6X14	Key
2	1	20011B	Head Body Cover	38	1	6X28	Key
3	2	ø62	Int Retaining Ring	39	2	ø8	Ball
4	2	ø35	Int Retaining Ring	40	2		Spring
5	1	20018B	Airtight Base	41	2	ø18	Ext Retaining Ring
6	2	45x35X10	Airtight Ring	42	1	5X50	Key
7	1	1.5KW	Motor (415V)	43	4	M6X12	Screw
8	1	M8X25	Screw	44	1	20107B	lii Shaft
9	1	8	Washer	45	1	20109-B	Gear Z25
10	1	20201	Plate	46	1	20110-2-B	Gear Z18
11	1	20304-1B	Arbor Bolt Cover	47	1	20112-B	Gear Z32
12	1	20304-2B	Arbor Bolt Cover Base	48	1	20113-B	Gear Z43
13	6	M8X45	Screw	49	1	20115-B	Gear Z16
14	2	8x40	Pin	50	1	5X50	Key
15	1	M10x10	Screw	51	1	6X18	Key
16	1	M10x8	Screw	52	1	6X18	Key
17	1	6X28	Key	53	1	20019	Spindle Sleeve
18	1	ZG3/8"	Bolt	54	1	20104B	Spindle
19	2	20020B	Cap	55	1	30207 /P5	Bearing
20	2	20307B	Speed Lever	56	1	30206 /P5	Bearing
21	2	3X18	Pin	57	1	20114-B	Splined Sleeve Z25
22	1	ZG3/8"	Oil Plug	58	1	20116-B	Gear Z53
23	3	M5x10	Screw	59	1	ø35	Ext Retaining Ring
24	6	M4X8	Screw	60	1	20012	Feed Base
25	1	M18X1.5	Oil Pointer	61	1	20128	Support Base
26	1	20105B	I Shaft	62	1	20129	Nut
27	1	20105-1-B	Gear Z14	63	1	20130	Knob
28	3	6003 / P5	Bearing	64	1	20131	Graduated Rod
29	3	6007 / P5	Bearing	65	1	20021	Fixed Bolt
30	1	5X25	Key	66	1	20132	Scale Board
31	1	20106B	li Shaft	67	1	ø30	Lock Washer
32	1	20108-B	Gear Z29	68	1	M30X1.5	Lock Nut
33	1	20110-1-B	Gear Z35	69	1	20308	Rubber Washer
34	1	20111-B	Gear Z21	70	1	M4X8	Screw
35	1	20106-1-B	Gear Z41	71	1	3X18	Split Pin
36	4	6202 / P5	Bearing	72	1	M8X30	Bolt

NOTE: SOME INDIVIDUAL PARTS MAY ONLY BE AVAILABLE AS AN ASSEMBLY

HEAD PARTS LIST

No.	Qty.	Code.	Name	No.	Qty.	Code.	Name
73	1	20024B	Separating Ring	108	1		Adjust Handle
74	1	20133B	Bearing Cover	109	1	20125B	Lever Shaft
75	1	M5 x 6	Screw (R8)	110	1	20022-1B	Lever
76	1	M5 x 4	Pin (R8)	111	1	20204-2B	Lever Bracket
77	1	20015	Worm Wheel Box	112	2	12	Ext Retaining Ring
78	1	20119	Worm Shaft	113	2	M6X16	Screw
79	1	20302	Worm Cover	114	1	20204-3B	Lever Rod
80	1	M6X12	Screw	115	2	12X22X8	Oil Seal
81	1	20120	Separating Ring	116	1	20126B	Long Lever Shaft
82	1	20016	Worm Wheel	117	1	20204-1B	Lever Bracket
83	1	20117	Pinion Shaft	118	1	20022-2B	Lever
84	1	20013	Handle Body	119	1	35x62x10	Oil Seal
85	1	20118	Spring Base				
86	1	20123	Spring Cap				
87	1	20122	Spring Plate				
88	1	20303	Big Ripple Handle				
89	1		Compression Spring				
90	1	20017	Graduated Plate				
91	1	20121B	Handle Rod				
92	1	20301B	Handle Ball				
93	1	20306B	Handle Wheel				
94	1	20305-B	Handle Rod				
95	2	M8X25	Screw				
96	1	10107	Screw				
97	1	203063	Washer				
98	1	203066	Screw				
99	3	M6X12	Screw				
100	1	M5X12	Screw				
101	2	3X12	Pin				
102	1	8X20	Key				
103	2	M5X20	Screw				
104	1	3X15	Pin				
105	1	20124B	Fixed Bolt				
106	1	20203B	Fixed Tight Block				
107	1	20202B	Fixed Tight Block				

NOTE: SOME INDIVIDUAL PARTS MAY ONLY BE AVAILABLE AS AN ASSEMBLY

COLUMN AND TABLE PARTS

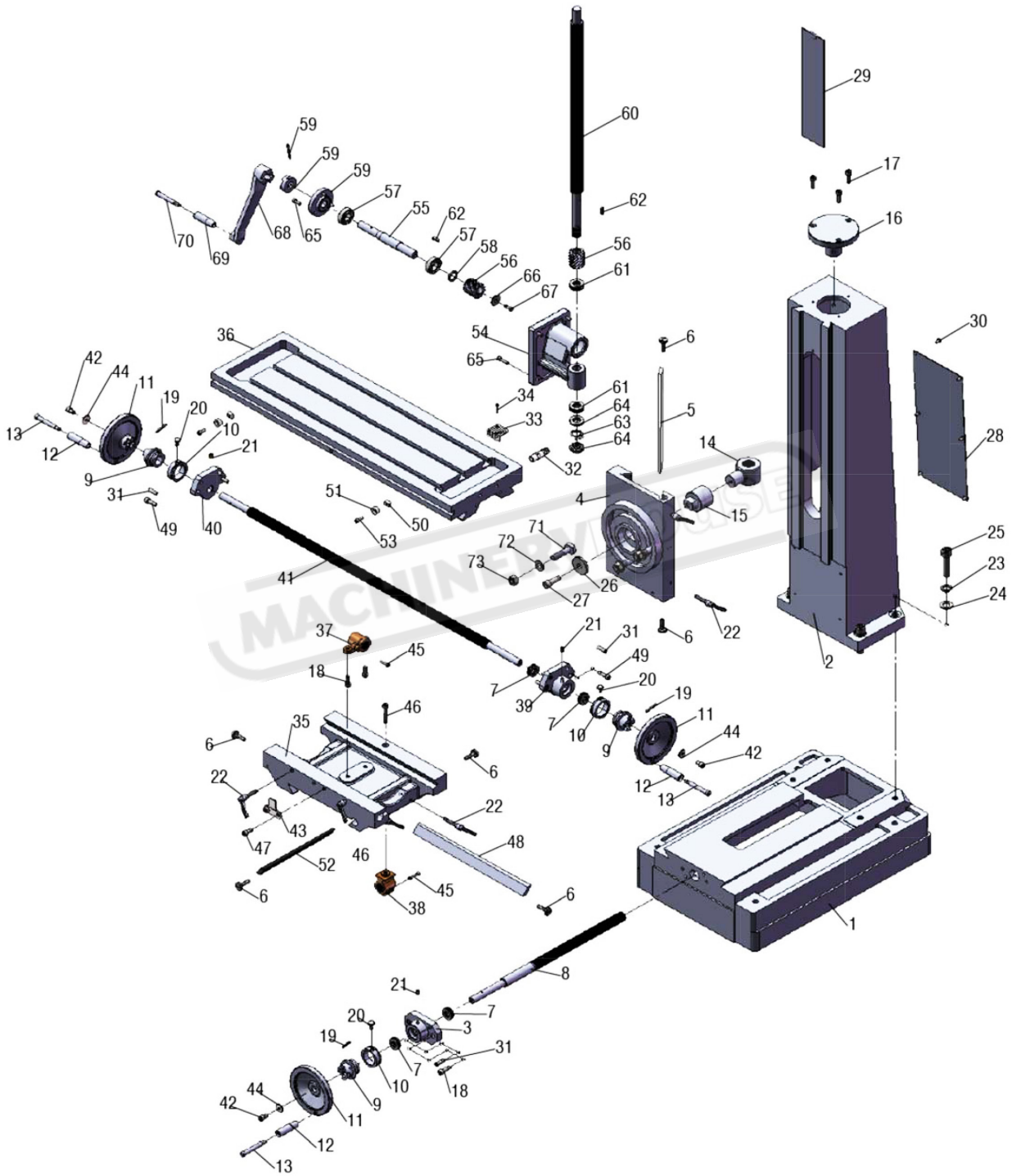

COLUMN AND TABLE PARTS LIST

No.	Qty.	Code.	Name	No.	Qty.	Code.	Name
1	1	10010	Base	42	3	M6x16	Screw
2	1	10013	Column	43	1	10105	Dial Clutch
3	1	10021	Square Flange	44	3	6	Washer
4	1	10016	Raise And Lower Base	45	2	M5X20	Screw
5	1	10025	Gib Strip	46	1	M8X45	Screw
6	6	10106	Screw	47	2	M8X15	Screw
7	4	51103	Bearing	48	1	10022	Gib Strip
8	1	10104	Table Screw	49	4	M8X25	Screw
9	3	10102	Dial Clutch	50	2	10108	Movable Fixed Block
10	3	10111	Graduated Plate	51	2	10109	Fixed Block Support
11	3	10301	Wheel	52	1	10023	Gib Strip
12	3	20305-1B	Turn Handle	53	2	M6 X 16	Screw
13	3	20305-1B	Screw	54	1	10017	Raise And Lower Base
14	1	10024	Nut	55	1	10113	Shaft
15	1	10117	Nut Bracket	56	2	20109	Gear
16	1	10014	Cover	57	2	6004	Bearing
17	3	M8x20	Screw	58	1	100218	Washer
18	4	M8X25	Screw	59	1	10015	Flange
19	3	5X35	Pin	60	1	10016	Raise And Lower Screw
20	2	10107	Screw	61	2	51104	Bearing
21	5	8	Oil Cup	62	2	6 X 20	Key
22	6	M8	Fixed Handle	63	1	20	Lock Washer
23	4	16	Washer	64	2	M20X1.5	Lock Nut
24	4	16	Washer	65	7	M6 X 20	Screw
25	4	M16X60	Bolt	66	1	20109.1	Washer
26	1	10120	Washer	67	1	M8x16	Screw
27	1	M12X35	Screw	68	1	10018	Handle
28	1	10119	Plate	69	1	10018.1	Turn Handle
29	1	10124	Protecting Cover	70	1	10018.2	Screw
30	6	M6X12	Screw	71	3	M14x55	Bolt
31	6	8X30	Pin	72	3	14	Washer
32	1		Pipe Joint	73	3	M14	Nut
33	1		Filter Screen				
34	2	M3x25	Screw				
35	1	10011	Center Base				
36	1	10012	Table				
37	1	10202	Table Nut				
38	1	10203	Table Base Nut				
39	1	10020	Right Flange				
40	1	10019	Left Flange				
41	1	10103	Table Screw				

NOTE: SOME INDIVIDUAL PARTS MAY ONLY BE AVAILABLE AS AN ASSEMBLY

WIRING DIAGRAM

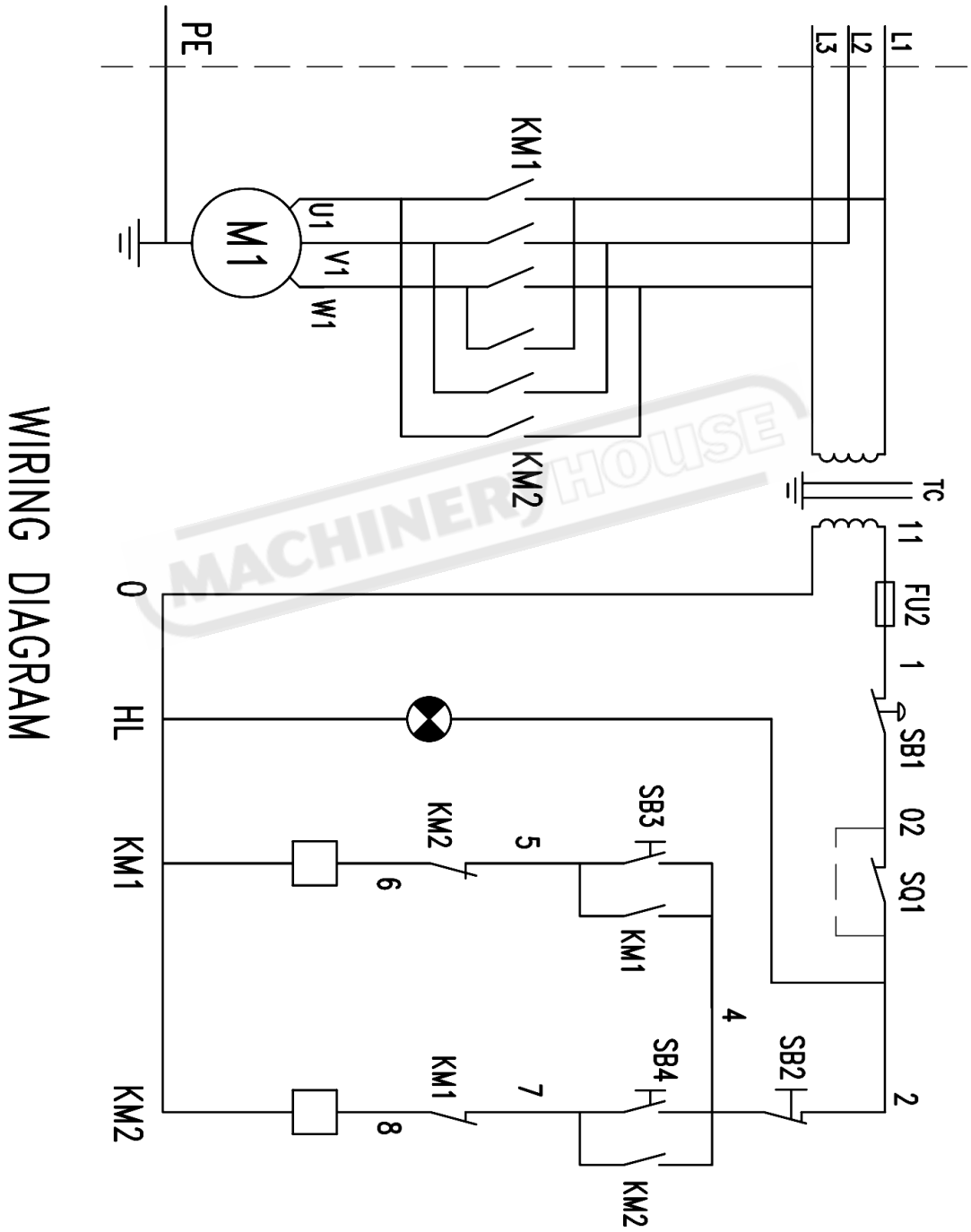

WIRING DIAGRAM